

Expertise. Experience. Innovation.



WEIRO® Site Welfare Trailer **CUSIC**



WEIRO® Site Welfare Trailer
CUSIC
the new generation of
recreation trailers

Sandwich construction, galvanized chassis, with ball hitch, as non braked, single axle trailer of 3.50 m body length with a total admissible weight of 750 kg; or with overrun brake and a maximum gross weight of up to 1,500 kg with body lengths of 3.00 to 6.00 m

www.weiro.de

Expertise. Experience. Innovation.



WEIRO® Site Welfare Trailer **CLASIC**

Specification

Chassis

- galvanized chassis
- ball hitch
- axle with full track rubber suspension, track width 165 cm
- tyres **195/50 – 10 TL**
- 4 adjustable **galvanized prop stands**
- lighting equipment 12 V



adjustable galvanized prop stands



sliding window with window shutters

Floor

- one piece sandwich element
- thermal insulation by polyurethane foam
- subfloor made from galvanized steel
- plywood, painted, optional with PVC-floor



bright, interior room

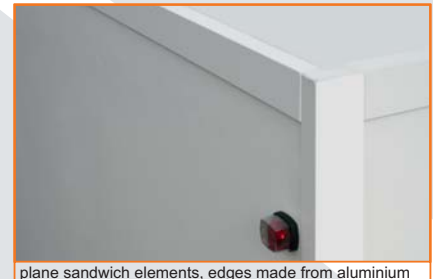

plane sandwich elements, edges made from aluminium

Body

- one piece sandwich elements
- outside lining by glas fiber reinforced plastic, 1,5 mm, UV resistant, white, other RAL colours by request
- inside lining by glas fiber reinforced plastic, 1,5 mm
- thermal insulation by polyurethane foam
- edges made from aluminium



door, optional with round glazing



special painting, available in all RAL colours

Door/Window

- steel door 875 x 2000 mm, profile cylinder lock, optional door glazing
- door check strap
- solid galvanized stair, 1-step
- sliding window 750 x 850 mm with safety glass; optional breaking and entering security

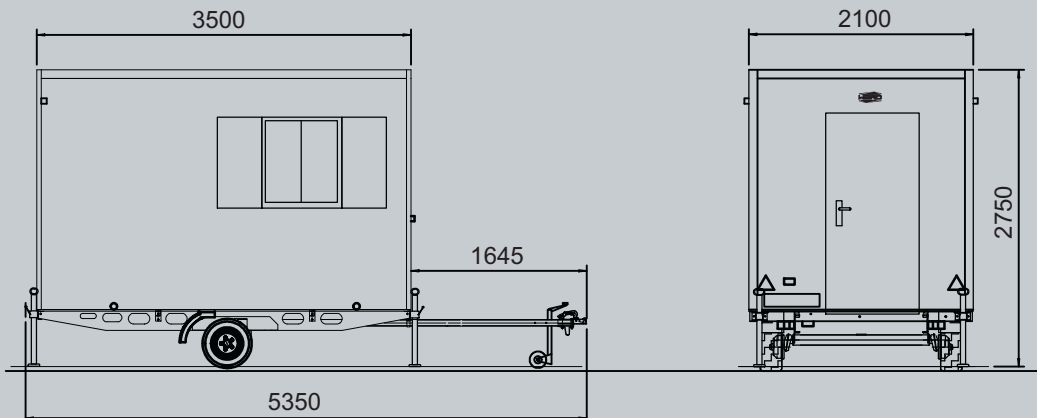

dimensions

	Total length	Body length	Body width	Internal	Outer height
recreation trailer CLASIC	ca. 5350 mm	ca. 3500 mm	ca. 2100 mm	ca. 2150 mm	ca. 2750 mm

Weisig Maschinenbau GmbH

Am Froberg 3 D-31061 Alfeld Tel. +49 (0) 5181 - 8448-0 Fax +49 (0) 5181 - 8448-44 info@weiro.de