

Expertise. Experience. Innovation.



Site Welfare Trailer
WEIRO® type BME-B 20 S



gross
vehicle weight
750 kg



RASANT BME-B 20 S

Site Welfare Trailer, single axle, with **ball hitch**, **body length of 3.20 m**, with **galvanised chassis**, unbraked, 80 km/h speed, permissible total weight 750 kg

WEIRO® **RASANT** type BME-B 20 S

Chassis:

- chassis made from **galvanized lightweight profiles**
- ball hitch
- tyres **195/55 – R 10**
- axle with full track rubber suspension, track width 165 cm
- 4 adjustable **galvanized prop stands**
- lighting equipment 12 V

Floor:

- one piece sandwich element
- subfloor made from **galvanized steel**
- **galvanized floor frame**
- thermal insulation by **polyurethane foam**
- painted plywood with optional skid resistant PVC floor

Body:

- nailed wooden framework
- plastic coated, profiled, galvanized steel sheet on outer walls. Standard RAL 7032, other RAL colours by request
- inside lining plastic coated wood material board, optional 10 mm particle board

- rock wool insulation

- edges made from galvanized steel, red/white coated

Door/Window:

- steel door 750 x 1,875 mm, profile cylinder lock, optional breaking and entering security
- solid **galvanized stair**, 1-step
- sliding window 750 x 850 mm with safety glass; optional breaking and entering security

Roof:

- strong, arched design
- **galvanized steel**, folded lengthways for strength, 2 galvanized steel gutters
- rock wool insulation
- inside lining plastic coated wood material board

empty weight (without furniture)

650 kg

gross vehicle weight

750 kg

Dimensions (mm)

Total Length	4,730 mm	Body Length	3,220 mm
Total Width	2,340 mm	Body Width	2,220 mm
Outer Height	3,020 mm	Inside Height	2,300 mm



pr chassis made from **galvanized lightweight profiles**, **galvanized prop stands**



solid **galvanized stair**, 1-step



Floor made from one piece sandwich element with subfloor made from **galvanized steel**, **galvanized floor frame**

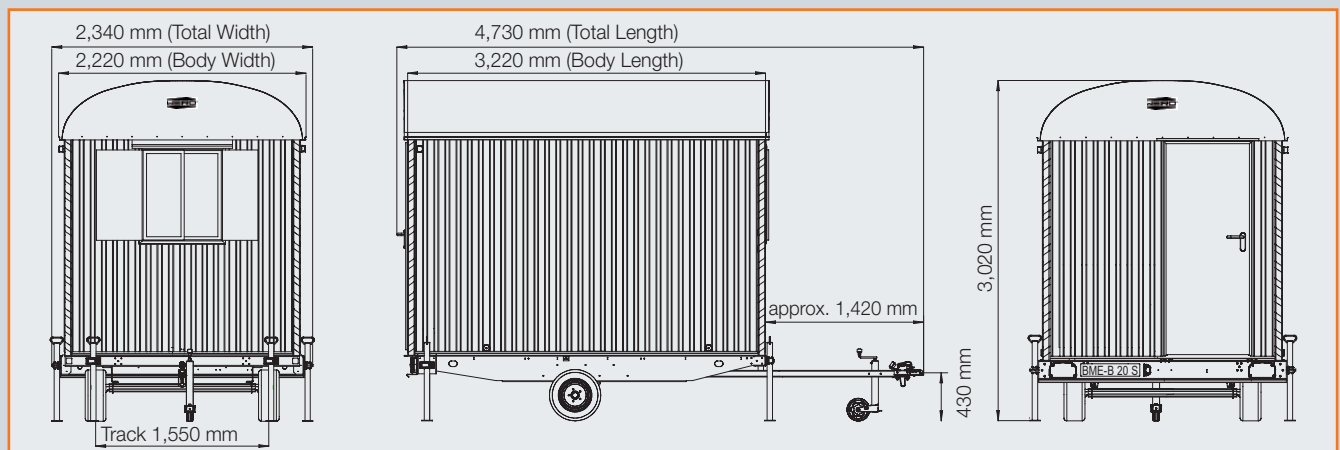

Weisig Maschinenbau GmbH

Am Froberg 3 31061 Alfeld Germany

Tel. +49 (0)5181-8448-0

Fax +49 (0)5181-8448-44

info@weiro.de