

Expertise. Experience. Innovation.



## WEIRO® TM 800 SH



TM 800 SH

Self-propelled bitumen sprayer on extremely manoeuvrable 3-wheel chassis for the reliable and accurate application of all kinds of cold-liquid tack coating materials and bitumen emulsions, including polymer modified binders

## WEIRO<sup>®</sup> TM 800 SH



Leading to quality: accurate binder spraying by computer assisted automatic dosage system (option), even spray pattern through advanced spraybar design.

### Options:

- Computer-aided dosage control system **WEIRO<sup>®</sup> Spraycontrol V4** for the automatic regulation of the preselected binder quantity (kg/m<sup>2</sup>), independent of working speed and working width
- Spraybar units in various working widths from 1.60 m to 2.30 m
- Tachometer (m/min) with digital display to monitor the working speed
- Electric auxiliary heater (230 VAC) to keep the binder warm overnight
- Rotating beacons in LED or flash technology
- Lifting brackets for hoisting the machine with a forklift
- Plug-in supporting wheels for driving on flat bed trailer
- **Hydraulically driven agitator** for circulating the binder in order to achieve even preheating using the gas burner system

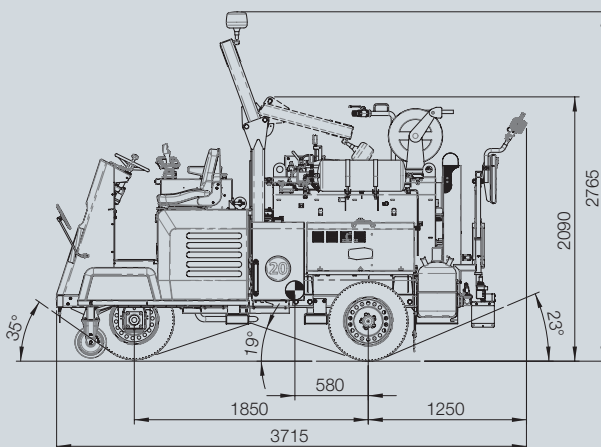

Self-propelled spraying machine **WEIRO<sup>®</sup> TM 800 SH** with a net capacity of 800 l to ensure the reliable layer bonding with polymer modified binders, e. g. according to TL BE-StB 15 (bitumen emulsion) and tack coat binders, equipped with ROPS (foldable), certified according to DIN EN ISO 3471:2010-01.

### Features:

- Driven by diesel engine (water-cooled), with diesel particulate filter, **emission stage V according to EU 2016/1628**
- Hydrostatic drive via electronic control lever with function keys, electronic cruise control
- Self-filling the bitumen emulsion by suction out of storage tanks or external filling through the tank dome
- Preheating the binder via the LPG burner system with thermostatic controller – level switch to power off the burner at lower binder level
- Accurate binder spraying on the road surface through the spraybar available in various working widths with electric single nozzle control
- Spraying width adjustment via preselection of individual nozzles on the driver's control panel
- Hand spraying with the hand spray unit
- Cleaning of the entire binder circuit and the spraybar nozzles by flushing with compressed air

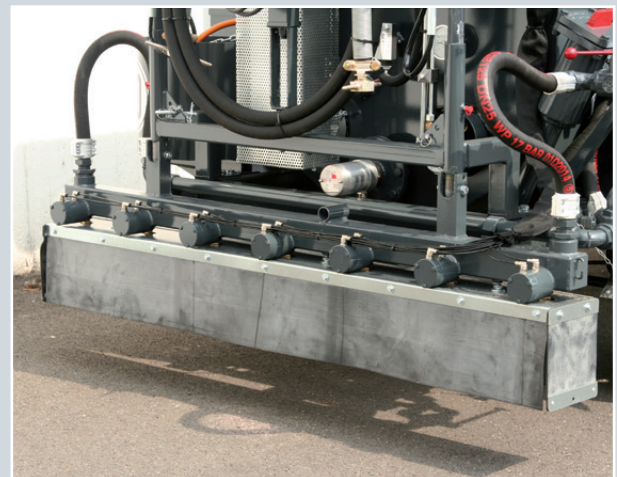

Spray bar with electro-pneumatic individual nozzle switching, optional: foldable spray bar extension.